



RNC 200
203 CFM @ 0.3 (75) IN. W.G. (PA)

DOOR PORT BALANCING & 3 SELECT HIGH-SPEED SETTINGS, FEATURING OUR PATENTED HEX CORE

- Cross Flow Core
- Door Port Balancing & Adjustable Dampers
- Outstanding Cold Weather Performance

NOTE: Front clearance of 25 in. (635 mm) is recommended for servicing unit. All ducts use 6 in. (152 mm) round collars. All units conform to CSA and UL standards.

DIMENSIONS

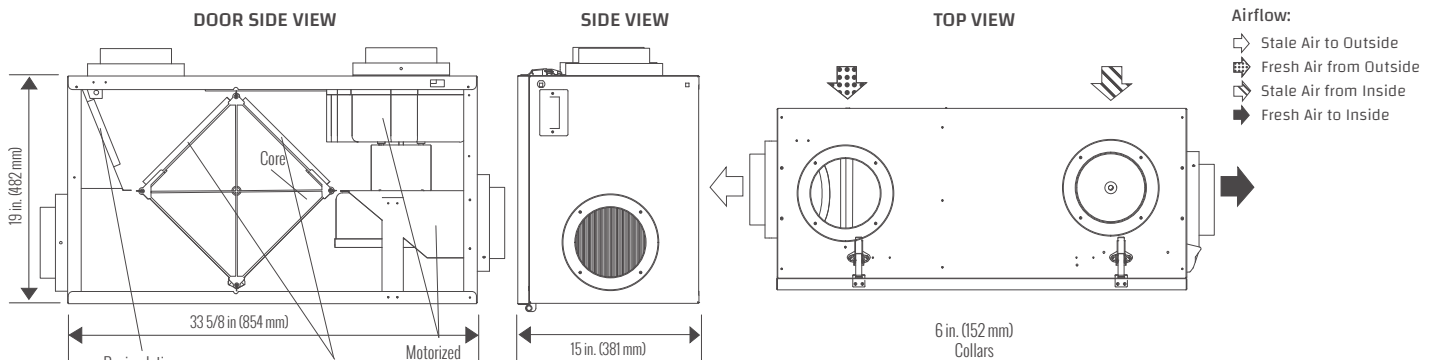

FEATURES

THERMALLY CONDUCTIVE CORE

Cross-flow heat recovery core transfers heat between two airstreams. It is easily removed for cleaning or service.

MOTORS AND BLOWERS

Each airstream has one centrifugal blower driven by a common PSC motor, with multiple fan speed operations.

MERV 6 FILTERS

Washable air filters in exhaust and supply airstreams.
MERV 13 Upgrade: 65-195-6R.

MOUNTING

Four threaded inserts at corners of the cabinet designed to accept the "S" hooks and hanging straps supplied with the unit

DEFROST

Intelligent recirculating damper defrost system.

CASE

22 gauge prepainted galvanized steel for superior corrosion resistance, insulated to prevent exterior condensation. Drain connections 2 - 1/2 in. (12 mm) OD. Balancing ports are located on door.

INSTALLER SELECTABLE HIGH SPEED SETTINGS

Adjustable DIP switches are located on the circuit board, Hi3 is the factory setting. Refer to the installation manual for adjustment instructions.

ELECTRONICS

The optional control can be wall mounted in a central location of the home. 3 wire 20 gauge (min.) 100 ft length (max.).

Weight: 71 lbs (32 KG) • Shipping Weight: 73 lbs (33 KG)

LIFEBREATH® RNC 200

Indoor Air Systems **HEAT RECOVERY VENTILATOR**

SPECIFICATIONS



MODEL:	RNC 200
VOLTAGE:	120 V
FREQUENCY:	60 Hz
WATTS @ 61 CFM (29 L/S):	74 W
CURRENT:	1.4 A
AIRFLOW @ 0.3:	203 CFM
WEIGHT:	71 lbs / 32 kg
DRAIN:	Yes
MCA:	2.0 A
MOP:	15 A
WARRANTY:	Units carry a lifetime warranty on the HRV core and a 5 year replacement parts warranty.



PERFORMANCE

IN. W.G. (PA)	0.2 (50) CFM (L/s)	0.3 (75) CFM (L/s)	0.4 (100) CFM (L/s)	0.5 (125) CFM (L/s)	0.6 (150) CFM (L/s)	0.7 (175) CFM (L/s)
Net Supply Airflow	214 (101)	203 (96)	191 (90)	174 (82)	153 (72)	123 (58)
Gross Supply Airflow	222 (105)	212 (100)	197 (93)	180 (85)	159 (75)	127 (60)
Gross Exhaust Airflow	195 (92)	184 (87)	174 (82)	157 (74)	129 (61)	87 (41)

**Sensible Effectiveness (ASE)
@ 63 CFM (30 L/s)** 32°F (0°C) 74%

**Sensible Efficiency (SRE)
@ 61 CFM (29 L/s)** 32°F (0°C) 65%

**Sensible Efficiency (SRE)
@ 70 CFM (33 L/s)** -13°F (-25°C) 60%

