

# LIFEBREATH® 267 MAX

Indoor Air Systems **HEAT RECOVERY VENTILATOR**



267 MAX  
267 CFM @ 0.3 (75) IN. W.G. (PA)

## DESIGNED FOR MID TO LARGE SIZED HOMES REQUIRING ULTRA-EFFICIENT VENTILATION IN A COMPACT SIZE

- ECM Motor provides higher output and very low power consumption
- DXPL03 Digital Wall Control included, for easy programmability
- Aluminum HEX Core with lifetime warranty

**NOTE:** Front clearance of 25 in. (635 mm) is recommended for servicing unit.  
All ducts use 6 in. (152 mm) oval collars.  
Balancing dampers are located on all collars.  
All units conform to CSA and UL standards.

## FEATURES

### THERMALLY CONDUCTIVE HEX CORE

Counter-flow heat recovery core transfers heat between two airstreams. It is easily removed for cleaning or service.

### MOTORS AND BLOWERS

ECM Motor provides higher output and very low power consumption. Each airstream has an independent centrifugal blower with multiple fan speed operation.

### MERV 6 FILTERS

Washable air filters in exhaust and supply airstreams.  
**MERV 13 Upgrade: 65-195-6R.**

### MOUNTING

Threaded inserts at corners of the cabinet designed to accept the "S" hooks and hanging straps supplied with the unit.

### DEFROST

Intelligent recirculating damper defrost system.

### CASE

22 gauge prepainted galvanized steel for superior corrosion resistance, insulated to prevent exterior condensation. Balancing ports are located on unit.

### ELECTRONICS

The DXPL03 control included with the unit can be wall mounted in a central location of the home. 3 wire 20 gauge (min.) 100 ft. length (max.).

## DIMENSIONS

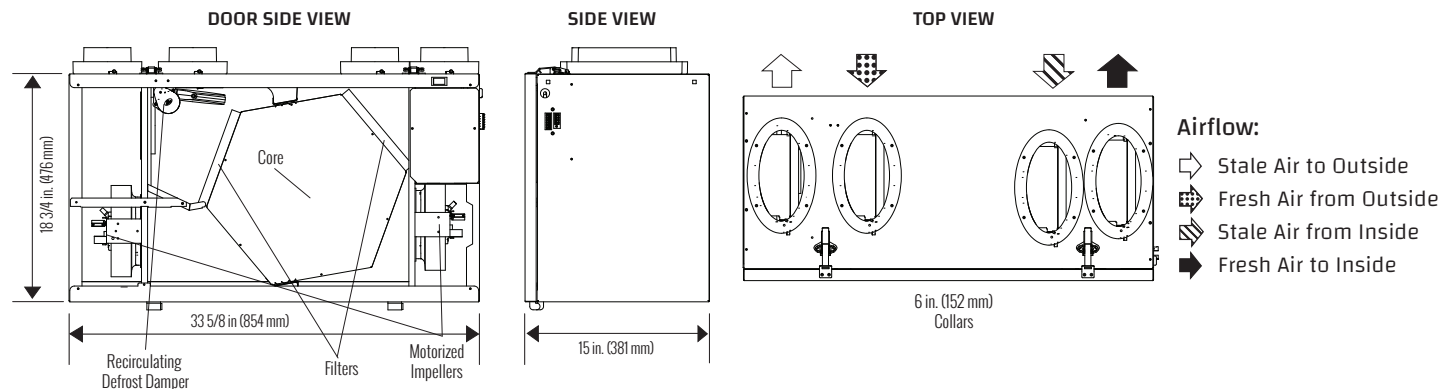

**Weight: 57 lbs (25.8 KG) • Shipping Weight: 67 lbs (30 KG)**

# LIFEBREATH<sup>®</sup> 267 MAX

Indoor Air Systems **HEAT RECOVERY VENTILATOR**



## SPECIFICATIONS

<b>MODEL:</b>	<b>267 MAX</b>
<b>VOLTAGE:</b>	120 V
<b>FREQUENCY:</b>	60 Hz
<b>WATTS @ 64 CFM (30 L/S):</b>	22 W
<b>CURRENT:</b>	2.1 A
<b>AIRFLOW @ 0.3:</b>	267 CFM
<b>WEIGHT:</b>	57 lbs / 25.8 kg
<b>DRAIN:</b>	Yes
<b>MCA:</b>	7.0 A
<b>MOP:</b>	15 A
<b>WARRANTY:</b>	Units carry a lifetime warranty on the HRV core and a 5 year replacement parts warranty.



## PERFORMANCE

IN. W.G. (PA)	0.2 (50) CFM (L/s)	0.3 (75) CFM (L/s)	0.4 (100) CFM (L/s)	0.5 (125) CFM (L/s)	0.6 (150) CFM (L/s)	0.7 (175) CFM (L/s)	0.8 (200) CFM (L/s)	0.9 (225) CFM (L/s)
<b>Net Supply Airflow</b>	271 (128)	267 (126)	261 (123)	254 (120)	248 (117)	242 (114)	233 (110)	227 (107)
<b>Gross Supply Airflow</b>	275 (130)	269 (127)	263 (124)	256 (121)	250 (118)	244 (115)	237 (112)	229 (108)
<b>Gross Exhaust Airflow</b>	307 (145)	301 (142)	292 (138)	286 (135)	278 (131)	271 (128)	265 (125)	256 (121)

**Sensible Effectiveness (ASE)  
@ 64 CFM (30 L/s)**      32°F (0°C)      84%

**Sensible Efficiency (SRE)  
@ 64 CFM (30 L/s)**      32°F (0°C)      75%

**Sensible Efficiency (SRE)  
@ 72 CFM (34 L/s)**      -13°F (-25°C)      70%

