



1230 ERV - ECM

## IDEAL FOR WARM HUMID AREAS WITH HEAVY AIR CONDITIONER USE

- Contains 3 AHRI 1060 Certified 68-280 Enthalpy Cores.
- Reversible access, E-box can be located on either side.
- Microprocessor circuit board with built in interlock contacts.
- ERV will transfer water vapor from supply to exhaust reducing AC load.
- High efficiency electronically commutated motors (ECM).

## DIMENSIONS

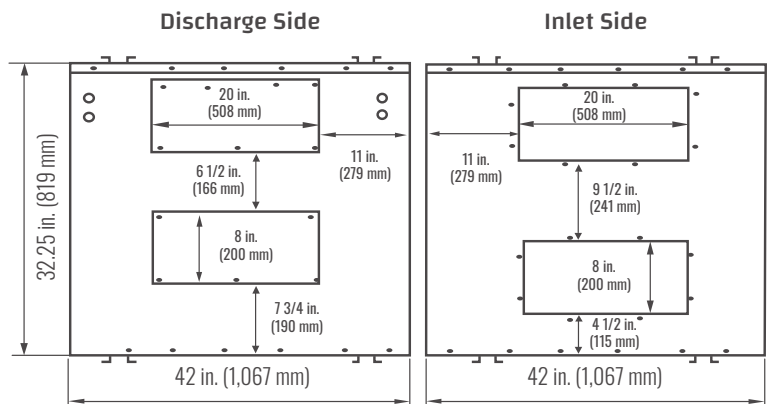
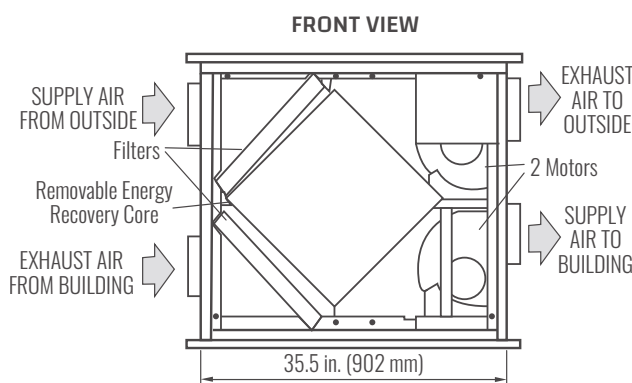

**Weight: 285 lbs (130 KG) • Shipping Weight: 335 lbs (152 KG)**

## FEATURES

### TOTAL RECOVERY CORE

The cross-flow energy recovery core transfers heat and water vapor between the two air streams. It is easily removed for cleaning or service.

### MOTORS

Two ECM, 3 speed double shafted, 120 VAC, 6.5A each(13.0A total on maximum speed). 1/2 HP, 2000 RPM Max. MCA: 16.3A, MOP: 25.0A. Total on high speed: 840 watts@ 0.5 in H2O.

### FILTERS

2 in. pleated MERV8 filters in supply and exhaust air streams. MERV 13 Upgrade: 65-238R.

### BLOWERS

Slide in / out easily of unit. Centrifugal type rated at 1200 CFM (566 L/s) free air delivery. Each air stream has one double shafted motor driving a centrifugal blower.

### CONNECTION DUCT SIZES

Four 20 in. x 8 in. (508 mm x 200 mm).

### MOUNTING

Unit to be set on support brackets hung by threaded rod type apparatus (brackets and rod not provided).

### CABINET

Unit has front and back access doors and electrical panel. 22 gauge prepainted galvanized steel (G60) for superior corrosion resistance. Insulated with foil faced insulation where required to prevent exterior condensation.

### ELECTRONICS

Integrated microprocessor circuit board. Built-in interlock contacts. Optional remote speed control.

### FROST PREVENTION

Temperature sensor activated, periodically shuts down supply motor. Drains not required.

# LIFEBREATH® 1230 ERV-ECM

Indoor Air Systems ENERGY RECOVERY VENTILATOR



AHRI 1060 Certified Core:  
Contains three 68-280



**NOTE:**

The 1230ERV - ECM model may easily be reversed in the field. Service clearance is 30 in. (760 mm) from front access doors.

**WARRANTY:**

Units carry a 5 year warranty on the ERV core and a 2 year replacement parts warranty.

All units conform to CSA and UL standards

Airflows (Each Air Stream)

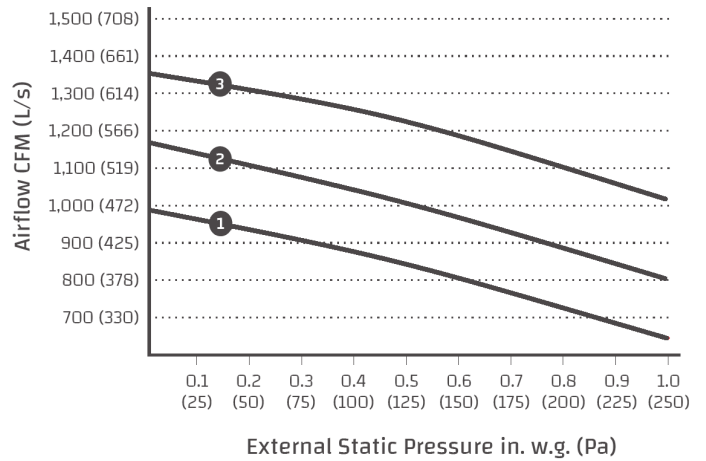

Total Effectiveness

